



CLEVIS HANGER

PLAIN FINISH, ELECTRO-GALVANIZED FINISH, & COPPER EPOXY COATING

Clevis Hangers are designed for suspension of non-insulated, stationary pipe lines.

For the suspension of insulated, stationary pipe lines, a shield is required; see Technical Data Sheet "Clevis Hanger with Welded Shield," for size and ordering information. The sheet consists of the welded assembly of shield welded to clevis hanger.



KEY BENEFITS

- UL® Listed
- FM Approved

DIMENSIONAL DATA

TABLE 1: DIMENSIONAL DATA

SIZE RANGE	1/2" through 4"
MATERIAL	Carbon steel; 304 (11SS) and 316 (11SX) stainless steel available on request.
FINISH	Plain finish, electro-galvanized finish, copper epoxy coating; hot dip galvanized available on request
SERVICE	Designed for the suspension of non-insulated, stationary pipelines.
MAX. TEMPERATURE	Plain 650° F, Galvanized and Epoxy 450° F
APPROVALS	U.L.-U.L.C. listed (sizes 2 1/2"-8") and FM approved (3/4"-8"). Complies with Federal Specification WW-H-171-E (Type# 1), A-A-1192A (Type# 1) and Manufacturers Standardization Society MSS SP-58 and SP-69 (Type# 1).
INSTALLATION	Hanger load nut above the clevis must be tightened securely to assure proper hanger performance.
ADJUSTMENT	Vertical adjustment is provided, varying with the size of clevis. Tighten upper nut after adjustment.
FEATURES	An economical attachment for light duty service.
ORDERING	Specify part number
NOTES	Upper lock nut must be tightened securely to assure proper hanger performance. Stainless steel hangers are recommended for applications where protection from corrosive environments is needed.
CAUTION	Hangers and supports shall be sized to fit the outside diameter of the pipe or tubing. When an oversize clevis is used, a pipe spacer or multi spacer should be placed over clevis bolt to ensure that the lower U-strap will not move in on the bolt.



CLEVIS HANGER

PLAIN FINISH, ELECTRO-GALVANIZED FINISH, & COPPER EPOXY COATING

DIMENSIONAL DATA

"E" dimension is measured from bottom of rod to centerline of pipe. *Exposed rod thread dimension is equal to the diameter of the rod used.

TABLE 2: DIMENSIONAL DATA OF CLEVIS HANGER – COPPER EPOXY COATED

CLEVIS HANGER – COPPER EPOXY COATED								
PART #	PIPE SIZE (IN.)	MAX LOAD (LBS.)	APPROX. WEIGHT PER PC.	ROD SIZE A	B	C	ROD TAKE OUT E	ADJUSTMENT F
6CHCE0012	1/2	150	0.22	3/8	2-1/2"	2-7/8"	1-1/2"	1-3/16"
6CHCE0034	3/4		0.20		2-5/8"	3-1/4"	1-5/8"	1-3/16"
6CHCE0100	1	250	0.20		2-3/4"	3-1/2"	1-3/4"	1-3/16"
6CHCE0114	1-1/4		0.22		2-7/8"	3-5/8"	1-7/8"	1-3/16"
6CHCE0112	1-1/2		0.18		3"	4"	2"	1-3/16"
6CHCE0200	2		0.24		3-3/8"	4-1/8"	1-3/8"	1-3/16"
6CHCE0212	2-1/2	350	0.28	1/2	4"	5"	3"	1-3/4"
6CHCE0300	3		0.70		4-5/8"	5-1/2"	3-5/8"	1-3/4"
6CHCE0400	4	400	0.90	5/8	5-1/4"	6-3/8"	4-1/4"	1-3/4"

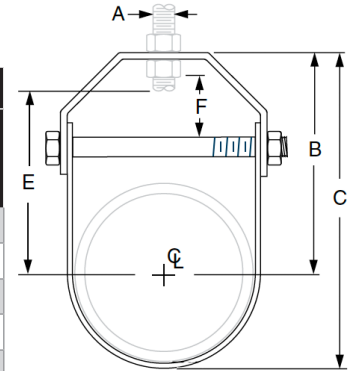

TABLE 3: DIMENSIONAL DATA OF CLEVIS HANGER – PLAIN FINISH AND ELECTRO-GALVANIZED FINISH

CLEVIS HANGER – PLAIN FINISH AND ELECTRO-GALVANIZED FINISH									
PLAIN PART #	ELE-GALV. PART #	PIPE SIZE (IN.)	MAX LOAD (LBS)	APPROX. WEIGHT PER PC.	ROD SIZE A	B	C	E*	F
6CHPL0012	6CHGV0012	1/2	600	.37	3/8	1-7/8"	2-3/8"	1/2"	1/2"
6CHPL0034	6CHGV0034	3/4		.38		2-1/8"	2-3/4"	5/8"	5/8"
6CHPL0100	6CHGV0100	1		.39		2-1/4"	2-7/8"	3/4"	3/4"
6CHPL0114	6CHGV0114	1-1/4		.40		2-7/8"	3-3/4"	2"	1-1/8"
6CHPL0112	6CHGV0112	1-1/2		.44		2-3/4"	3-3/4"	2-1/16"	1"
6CHPL0200	6CHGV0200	2		.52		3-1/2"	4-3/4"	2-5/16"	1-1/8"
6CHPL0212	6CHGV0212	2-1/2	1100	1.08	1/2	4-1/2"	6"	2-3/8"	1-3/8"
6CHPL0300	6CHGV0300	3		1.20		4-1/2"	6-1/4"	2-7/8"	1-3/8"
6CHPL0400	6CHGV0400	4	1400	1.84	5/8	5-3/8"	7-3/4"	3-5/8"	1-1/2"
6CHPL0500	6CHGV0500	5		2.05		6-1/2"	9-3/8"	4-1/4"	2"
6CHPL0600	6CHGV0600	6	2000	3.10		7-7/8"	11-1/4"	5-1/4"	2"
-	6CHGV0800	8		4.40		8"	12-3/8"	6-5/8"	2-1/4"
-	6CHGV1000	10	3600	8.60	7/8	9-7/8"	15-1/4"	8-3/8"	2-1/4"
-	6CHGV1200	12	3800	10.40		11-3/4"	17-1/2"	9-3/4"	2-5/8"