



ICC-ES Evaluation Report ESR-3975

Reissued September 2021

Revised March 2023

This report is subject to renewal September 2023.

DIVISION: 05 00 00—METALS
Section: 05 05 27—Metal Connectors

REPORT HOLDER:

ALLFASTENERS USA

EVALUATION SUBJECT:

NEXGEN2™ ONESIDE BLIND BOLTS

1.0 EVALUATION SCOPE

Compliance with the following code:

- 2021, 2018, 2015, 2012 and 2009 *International Building Code*® (IBC)
- 2013 *Abu Dhabi International Building Code* (ADIBC)†

†The ADIBC is based on the 2009 IBC. 2009 IBC code sections referenced in this report are the same sections in the ADIBC.

For evaluation for compliance with codes adopted by Los Angeles Department of Building and Safety (LADBS), see [ESR-3975 LABC Supplement](#).

Property evaluated:

Structural

2.0 USES

NexGen2™ OneSide Blind Bolts are designed for connecting structural steel to hollow structural section (HSS) steel members and other structural steel elements where access is difficult or restricted to one side only. NexGen2™ OneSide Blind Bolts are intended for use with rectangular or square HSS members and are recognized for resisting tension and shear loads in bearing-type connections. NexGen2™ OneSide Blind Bolts are alternatives to bolts described in Section J3 of AISC 360, which is referenced in Section 2205.1 of the IBC, for bearing-type connections.

The NexGen2™ OneSide Blind Bolts may be used to resist wind loads, and seismic loads in Seismic Design Categories (SDC) A, B, and C in accordance with Section 1613.2.5 of the 2021 and 2018 IBC, Section 1613.3.5 of the 2015 and 2012 IBC, and Section 1613.5.6 of the 2009 IBC.

3.0 DESCRIPTION

3.1 General:

NexGen2™ OneSide Blind Bolts are assembled from five components, consisting of a steel core bolt, a shear sleeve

with steel spring, a hex nut, a solid collar washer and a collapsible split washer. The steel core bolt features a rounded head, threaded shank and tension control spline. The spring sleeve is a steel hollow cylinder with a premounted high tensile strength wire spring. The NexGen2™ OneSide Blind Bolt nominal diameter is 20 mm with lengths of 95, 135, 175 and 250 mm. Figure 1 provides an image of the NexGen2™ OneSide Blind Bolt.

3.2 Materials:

3.2.1 Core Bolt: The core bolt is manufactured from steel complying with ASTM A490M with a minimum specified F_u of 150,000 psi (1034 MPa), a 29 mm outer diameter rounded head and a double hex splined end.

3.2.2 Shear Sleeve with Steel Spring: The shear sleeve is manufactured from steel complying with ASTM A29 (4140) with a minimum specified F_u of 120,000 psi (827 MPa). The steel spring is manufactured from wire complying with ASTM A228 with a 0.050-inch diameter. The spring is used to hold the shear sleeve in the correct position.

3.2.3 Hex Nut: The hex nut is a prelubricated M20-2.50 heavy hex nut manufactured from steel complying with ASTM A194 2H.

3.2.4 Solid Collar Washer: The solid collar washer is manufactured from steel complying with 1045 HRC 23-24.

3.2.5 Collapsible Split Washer: The collapsible split washer is manufactured from steel complying with 1045 HRC 23-24

3.2.6 Finish Coating: All NexGen2™ OneSide Blind Bolt components are Magni 554 duplex coated to a minimum thickness of 13 microns.

4.0 DESIGN AND INSTALLATION

4.1 Design:

The NexGen2™ OneSide Blind Bolts are alternatives to bolts described in Section J3 of AISC 360, which is referenced in Section 2205.1 of the IBC, for bearing-type connections. The design of the NexGen2™ OneSide Blind Bolts must comply with this report, Section J3 of AISC 360 and the strength design information for the NexGen2™ OneSide Blind Bolts provided in this report. The load-carrying capacity of the assembly depends on the bolts, the type of steel elements connected (such as HSSs), and their cross

sections (thickness). The design strength is limited by the strength of the weakest component in the bolted assembly, which includes the affected elements of members and connecting elements and the bolts. The capacity may be governed by the affected elements and/or connecting elements in the case of thin sections, or the NexGen2™ OneSide Blind Bolt in the case of thick wall sections (or a combination of the two). All limit states must be checked to determine the load-carrying capacity of the assembly. Combined tension and shear loading must comply with the following:

$$\left(\frac{\text{Tension Demand}}{\text{Tension Capacity}}\right)^2 + \left(\frac{\text{Shear Demand}}{\text{Shear Capacity}}\right)^2 \leq 1.0$$

4.2 Installation:

The NexGen2™ OneSide Blind Bolts must be installed in accordance with the details noted in this section, the manufacturer's installation instructions and the approved plans.

1. Holes must be drilled into the steel sections to be connected, ensuring that the resulting holes have the correct diameter and spacing according to the manufacturer's published specifications, and the correct design requirements for the connection, as indicated in the approved plans. Holes must be 30 mm diameter.
2. Burrs in the holes must be removed before insertion of the NexGen2™ OneSide Blind Bolts. Field drilled holes shall be protected with cold-galvanized compound.
3. The structural steel elements to be connected must be positioned adjacent to each other to ensure that the two sections are lined up and bearing against the other without any gaps. Clamps may be used to hold the two steel sections together and prevent formation of gaps.
4. The NexGen2™ OneSide Blind Bolt must be installed in the holes in accordance with Figure 3.
5. Torque is applied until the bolt spline separates from the bolt.
6. The sheared bolt end of the NexGen2™ OneSide Blind Bolt is protected with cold-applied galvanizing compound.

4.3 Special Inspection:

Special inspection is required in accordance with Sections 1705.1 and 1705.2 of the 2021, 2018, 2015 and 2012 IBC (Sections 1704.3 and 1704.15 of the 2009 IBC). The manufacturer must submit inspection procedures to verify proper installation of the NexGen2™ OneSide Blind Bolts. Where NexGen2™ OneSide Blind Bolts are used for seismic or wind load resistance, special inspection requirements must comply with Sections 1704.3 and 1705 of the 2021, 2018, 2015 and 2012 IBC (Sections 1705, 1706 and 1707 of the 2009 IBC).

5.0 CONDITIONS OF USE

The NexGen2™ OneSide Blind Bolts described in this report comply with, or are suitable alternatives to what is specified in, the code noted in Section 1.0 of this report, subject to the following conditions:

- 5.1 Calculations and details showing that the NexGen2™ OneSide Blind Bolts are adequate to resist the applied

loads must be submitted to the code official for approval. The connected steel base materials and connecting steel elements also must be adequate to support the applied loads. The calculations and details must be signed and sealed by a registered design professional, when required by the statutes of the jurisdiction in which the project is to be constructed.

- 5.2 Fire-resistive construction: Where not otherwise prohibited in the code, NexGen2™ OneSide Blind Bolts are permitted for use with fire-resistance-rated construction provided that at least one of the following conditions is fulfilled:

- The NexGen2™ OneSide Blind Bolts are used to resist wind or seismic forces only.
- NexGen2™ OneSide Blind Bolts that support a fire-resistance-rated envelope or a fire-resistance-rated membrane, are protected by approved fire-resistance-rated materials, or have been evaluated for resistance to fire exposure in accordance with recognized standards.
- The NexGen2™ OneSide Blind Bolts are used to support nonstructural elements.

- 5.3 Special inspection must be provided as specified in Section 4.3 of this report.

- 5.4 Use of the NexGen2™ OneSide Blind Bolts in applications where the applicable code requires slip-critical installation is beyond the scope of this report.

- 5.5 Corrosion resistance of the NexGen2™ OneSide Blind Bolts and connected steel elements is outside the scope of this evaluation.

- 5.6 Use of the NexGen2™ OneSide Blind Bolt is limited to Seismic Design Categories (SDC) A, B, and C.

6.0 EVIDENCE SUBMITTED

Data in accordance with the ICC-ES Acceptance Criteria for OneSide Blind Bolts in Structural Steel Connections (AC437), dated June 2022.

7.0 IDENTIFICATION

- 7.1 The ICC-ES mark of conformity, electronic labeling, or the evaluation report number (ICC-ES ESR-3975) along with the name, registered trademark, or registered logo of the report holder must be included in the product label.

- 7.2 In addition, the NexGen2™ OneSide Blind Bolt is identified by a seven-character part number (2NGXXXX). The first three characters (2NG) indicate the product is an Allfasteners NexGen2™ OneSide Blind Bolt, the next two digits denote the diameter and the last two digits indicate the length. Each package of the NexGen2™ OneSide Blind Bolts includes the following information: NexGen2™ OneSide Blind Bolt product nomenclature, quantity, part number, lot number, and an image of the product.

- 7.3 The report holder's contact information is the following:

ALLFASTENERS USA
959 LAKE ROAD
MEDINA, OHIO 44256
(440) 232-6060
www.allfasteners.com

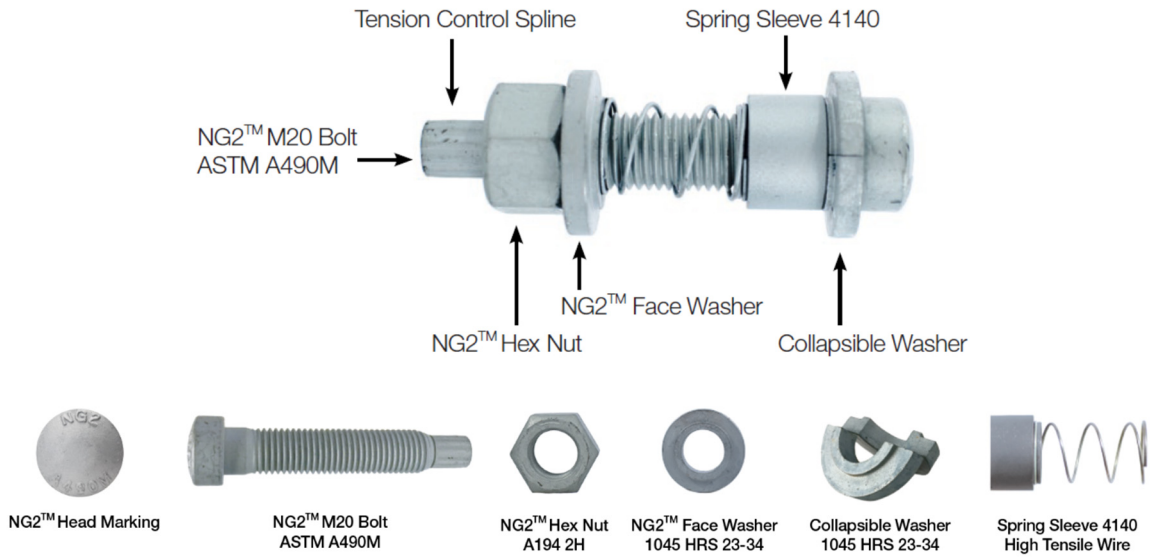

FIGURE 1—NEXGEN2™ ONESIDE BLIND BOLT

TABLE 1—NEXGEN2™ ONESIDE BLIND BOLT TECHNICAL DATA

Part Number	DIMENSIONAL INFORMATION					Drill Diameter (mm)
	Core Bolt Diameter (mm)	Core Bolt Length (mm)	Grip Range (in.)		Sleeve Length (in.)	
			Min.	Max.		
2NG2036	20	95	0.9375	1.4375	0.6875	30
2NG2048	20	95	1.4375	1.8750	1.1875	30
2NG2057	20	95	1.8750	2.1250	1.6250	30
2NG2068	20	135	2.1250	2.6875	2.0000	30
2NG2096	20	135	2.6875	3.7500	2.4375	30
2NG2127	20	175	3.7500	5.1875	3.0000	30
2NG2212	20	250	5.0000	8.3125	4.0000	30

For SI: 1 inch = 25.4 mm

TABLE 2—NEXGEN2™ LRFD SHEAR DESIGN STRENGTH BASED ON THE EXTERIOR PLY^{1,2,3,4,5,6}

LRFD Bolt Shear Design Strength (kips)						
ASTM A53-35	ASTM A36	ASTM A572-42	ASTM A572-50	ASTM A572-55	ASTM A572-60	ASTM A572-65
38.6	37.3	38.6	41.8	45.0	46.5	46.5

For SI: 1 kip = 4.448 kN

1. LRFD Design Strength based on resistance factor $\phi = 0.63$. For ASD Allowable Strength, divide tabulated values by 0.63 and then divide by safety factor $\Omega = 2.53$.
2. The shear sleeve must extend into the shear plane a minimum of 0.3125 in. (7.9 mm).
3. The exterior ply thickness must not be less than 0.500 in. (12.7 mm). The interior ply thickness must not be less than 0.1875 in. (4.8 mm).
4. The exterior ply and interior ply material tensile strengths (F_u) must not be less than 58 ksi (400 MPa).
5. The distance between centers of bolt holes must not be less than 3.0 in. (76 mm). The distance between the centers of the bolt holes and the end of the steel elements to be connected must not be less than 1.5 in. (38 mm).
6. These design strengths represent the minimum individual bolt capacity for a bolt located within an end connection.

TABLE 3—NEXGEN2™ LRFD SHEAR DESIGN STRENGTH BASED ON THE INTERIOR PLY ^{1,2,3,4,5,6}

LRFD Bolt Shear Design Strength (kips)							
Interior Ply Thickness, t (in.)	Interior Ply Material Grade						
	ASTM A53-35	ASTM A36	ASTM A572-42	ASTM A572-50	ASTM A572-55	ASTM A572-60	ASTM A572-65
0.1875 (³ / ₁₆)	18.4	17.7	18.4	19.9	21.4	22.9	24.5
0.2188 (⁷ / ₃₂)	21.4	20.7	21.4	23.2	25.0	26.8	28.5
0.2500 (¹ / ₄)	24.5	23.7	24.5	26.5	28.5	30.6	32.6
0.2813 (⁹ / ₃₂)	27.5	26.6	27.5	29.8	32.1	34.4	36.7
0.3125 (⁵ / ₁₆)	30.6	29.6	30.6	33.1	35.7	38.2	40.8
0.3438 (¹¹ / ₃₂)	33.6	32.5	33.6	36.4	39.3	42.1	44.9
0.3750 (³ / ₈)	36.7	35.5	36.7	39.8	42.8	45.9	46.5
0.4063 (¹³ / ₃₂)	39.8	38.4	39.8	43.1	46.4	46.5	46.5
0.4375 (⁷ / ₁₆)	42.8	41.4	42.8	46.4	46.5	46.5	46.5
0.4688 (¹⁵ / ₃₂)	45.9	44.3	45.9	46.5	46.5	46.5	46.5
≥ 0.5000 (¹ / ₂)	46.5	46.5	46.5	46.5	46.5	46.5	46.5

For SI: 1 inch = 25.4 mm; 1 kip = 4.448 kN

1. LRFD Design Strength based on resistance factor $\phi = 0.63$. For ASD Allowable Strength, divide tabulated values by 0.63 and then divide by safety factor $\Omega = 2.53$.
2. The shear sleeve must extend into the shear plane a minimum of 0.3125 in. (7.9 mm).
3. The exterior ply thickness must not be less than 0.500 in. (12.7 mm). The interior ply thickness must not be less than 0.1875 in. (4.8 mm).
4. The exterior ply and interior ply material tensile strengths (F_u) must not be less than 58 ksi (400 MPa).
5. The distance between centers of bolt holes must not be less than 3.0 in. (76 mm). The distance between the centers of the bolt holes and the ends of the steel elements to be connected must not be less than 1.5 in. (38 mm).
6. These design strengths represent the minimum individual bolt capacity for a bolt located within an end connection.

TABLE 4—NEXGEN2™ LRFD TENSION DESIGN STRENGTH BASED ON THE INTERIOR AND EXTERIOR PLYS ^{-1,2,3,4,5,6}

LRFD Bolt Tension Design Strength (kips)							
Interior Ply Thickness, t (in.)	Ply Material Grade						
	ASTM A53-35	ASTM A36	ASTM A572-42	ASTM A572-50	ASTM A572-55	ASTM A572-60	ASTM A572-65
0.1875 (³ / ₁₆)	20.5	21.1	24.6	28.6	30.8	33.0	33.8
0.2188 (⁷ / ₃₂)	24.0	24.6	28.7	33.4	33.8	33.8	33.8
0.2500 (¹ / ₄)	27.4	28.2	32.9	33.8	33.8	33.8	33.8
0.2813 (⁹ / ₃₂)	30.8	31.7	33.8	33.8	33.8	33.8	33.8
0.3125 (⁵ / ₁₆)	33.8	33.8	33.8	33.8	33.8	33.8	33.8
≥ 0.375 (³ / ₈)	33.8	33.8	33.8	33.8	33.8	33.8	33.8

For SI: 1 inch = 25.4 mm; 1 kip = 4.448 kN

1. LRFD Design Strength is based on a resistance factor $\phi = 0.63$. For ASD Allowable Strength, divide tabulated values by 0.63 and then divide by safety factor $\Omega = 2.53$.
2. The shear sleeve must extend into the shear plane a minimum of 0.3125 in. (7.9 mm).
3. The exterior ply thickness must not be less than 0.500 in. (12.7 mm). The interior ply thickness must not be less than 0.1875 in. (4.8 mm).
4. The exterior ply and interior ply material tensile strengths (F_u) must not be less than 58 ksi (400 MPa).
5. The distance between centers of bolt holes must not be less than 3.0 in. (76 mm). The distance between the centers of the bolt holes and the ends of the steel elements to be connected must not be less than 1.5 in. (38 mm).
6. These design strengths represent the minimum individual bolt capacity for a bolt located within an end connection.

TYPICAL NG2™ BOLT DETAIL: *PRE-TENSION*

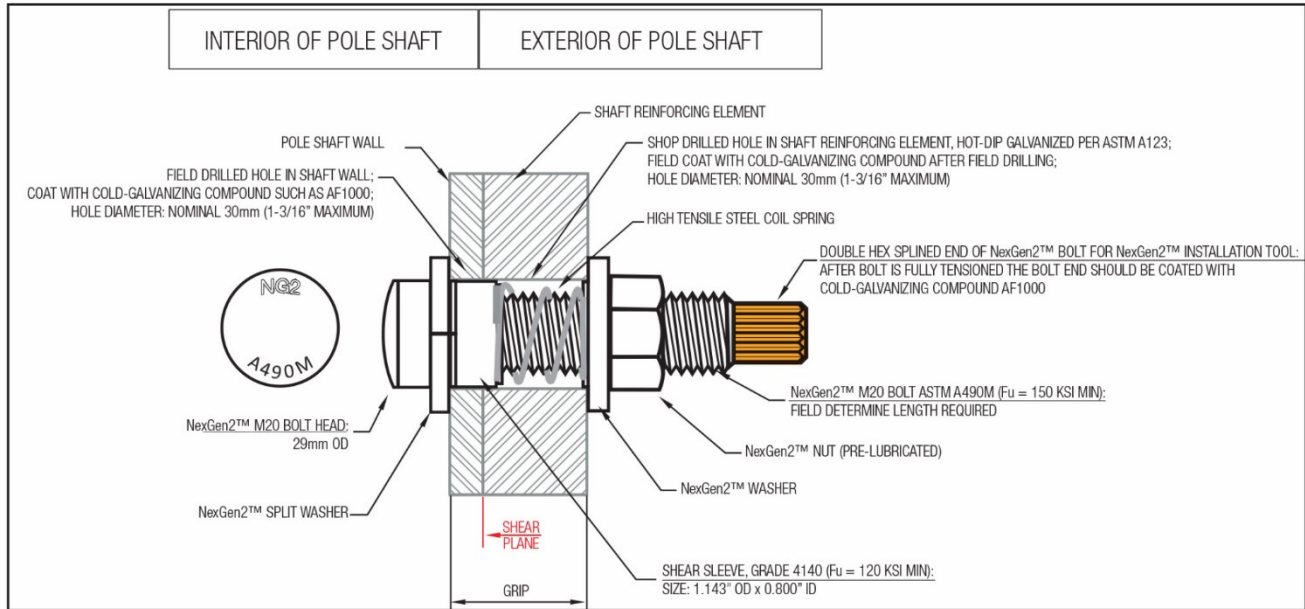

TYPICAL NG2™ BOLT DETAIL: *POST-TENSION*

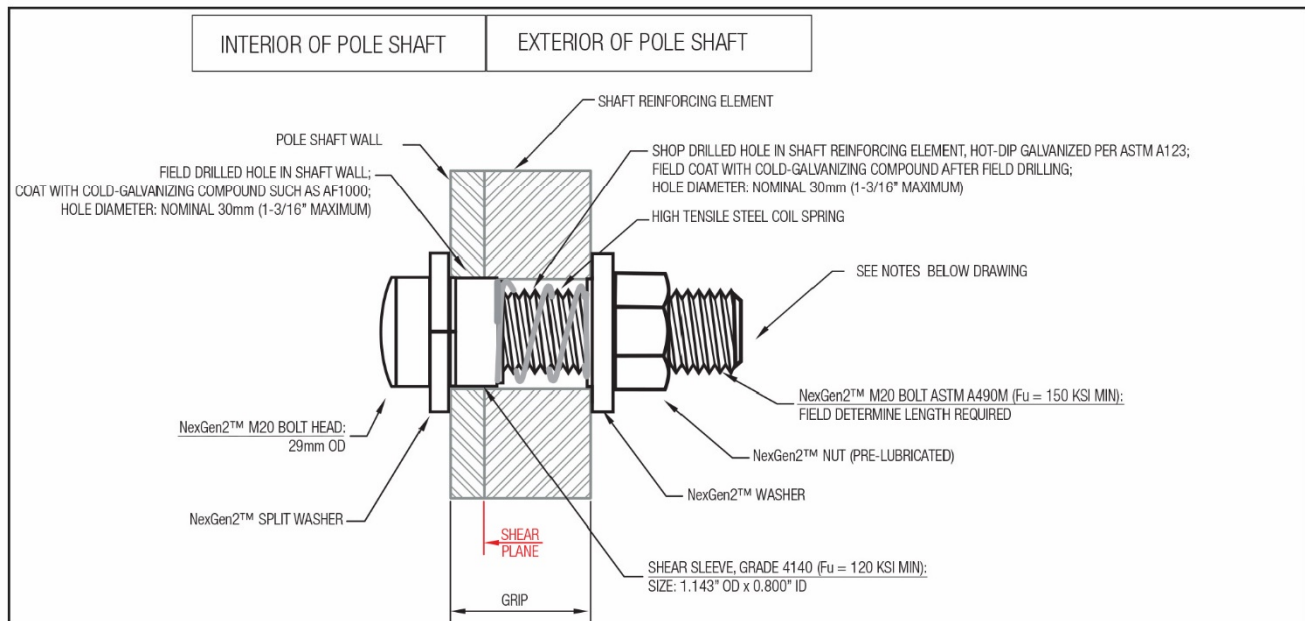

FIGURE 2—NEXGEN™ ONESIDE BLIND BOLT INSTALLATION DETAILS

PRE-INSTALL BOLT ON INSTALL TOOL:



INSTALLATION:

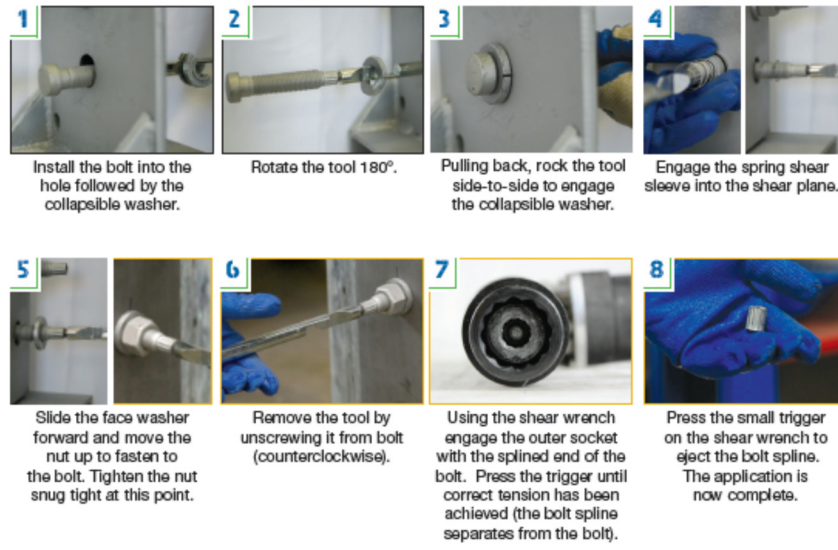

FIGURE 3—NEXGEN2™ ONESIDE BLIND BOLT INSTALLATION INSTRUCTIONS

DIVISION: 05 00 00—METALS

Section: 05 05 27—Metal Connectors

REPORT HOLDER:

ALLFASTENERS USA

EVALUATION SUBJECT:

NEXGEN2™ ONESIDE BLIND BOLTS

1.0 REPORT PURPOSE AND SCOPE

Purpose:

The purpose of this evaluation report supplement is to indicate that Nexgen2™ OneSide Blind Bolts, described in ICC-ES evaluation report [ESR-3975](#), have also been evaluated for compliance with the codes noted below as adopted by the Los Angeles Department of Building and Safety (LADBS).

Applicable code editions:

- 2023 *City of Los Angeles Building Code* (LABC)

2.0 CONCLUSIONS

The Nexgen2™ OneSide Blind Bolts, described in Sections 2.0 through 7.0 of the evaluation report [ESR-3975](#), comply with the LABC Chapter 22 and are subject to the conditions of use described in this supplement.

3.0 CONDITIONS OF USE

The Nexgen2™ OneSide Blind Bolts described in this evaluation report supplement must comply with all of the following conditions:

- All applicable sections in the evaluation report [ESR-3975](#).
- The design, installation, conditions of use and identification of the Nexgen2™ OneSide Blind Bolts are in accordance with the 2021 *International Building Code*® (IBC) provisions noted in the evaluation report [ESR-3975](#).
- The design, installation and inspection are in accordance with additional requirements of LABC Chapters 16, 17 and 22, as applicable.

This supplement expires concurrently with the evaluation report, issued September 2021 and revised March 2023.

DIVISION: 05 00 00—METALS

Section: 05 05 27—Metal Connectors

REPORT HOLDER:

ALLFASTENERS USA

EVALUATION SUBJECT:

NEXGEN2™ ONESIDE BLIND BOLTS

1.0 REPORT PURPOSE AND SCOPE

Purpose:

The purpose of this evaluation report supplement is to indicate that Nexgen2™ OneSide Blind Bolts, described in ICC-ES evaluation report ESR-3975, have also been evaluated for compliance with the code noted below.

Applicable code edition:

2022 California Building Code® (CBC)

For evaluation of applicable Chapters adopted by the California Office of Statewide Health Planning and Development (OSHPD) AKA: California Department of Health Care Access and Information (HCAI) and the Division of State Architect (DSA), see Sections 2.1.1 and 2.1.2 below.

2.0 CONCLUSIONS

2.1 CBC:

The Nexgen2™ OneSide Blind Bolts, described in Sections 2.0 through 7.0 of the evaluation report ESR-3975, comply with CBC Chapter 22, provided the design and installation are in accordance with the 2021 *International Building Code*® (IBC) provisions noted in the evaluation report and the additional requirements of CBC Chapters 16, 17 and 22, as applicable.

2.1.1 OSHPD: The applicable OSHPD Sections and Chapters of the CBC are beyond the scope of this supplement.

2.1.2 DSA: The applicable DSA Sections and Chapters of the CBC are beyond the scope of this supplement.

This supplement expires concurrently with the evaluation report, reissued September 2021 and revised March 2023.